

INDEX

- Simple mechanisms
- Motion and Turning Moment
- Power Transmission
- Vehicle in Motion
- Vehicle Control
- Balancing
- Vibration

Simple Mechanism

Mechanism: the fundamental physical or chemical processes involved in or responsible for an action, reaction or other natural phenomenon.

Machine: an assemblage of parts that transmit forces, motion and energy in a predetermined manner.

Simple Machine: any of various elementary mechanisms having the elements of which all machines are composed. Included in this category are the lever, wheel and axle, pulley, inclined plane, wedge and the screw.

A **machine** is a combination of rigid or resistant bodies, formed and connected so that they move with definite relative motions and transmit force from the source of power to the resistance to be overcome. A machine has two functions: transmitting definite relative motion and transmitting force. These functions require strength and rigidity to transmit the forces.

The word **mechanism** has many meanings. In Kinematics, a mechanism is a means of transmitting, controlling, or constraining relative movement. Movements which are electrically, magnetically, pneumatically operated are excluded from the concept of mechanism. The central theme for mechanisms is rigid bodies connected together by joints.

Rigid Body: is that body whose changes in shape are negligible compared with its overall dimensions or with the changes in position of the body as a whole, such as rigid link, rigid disc.....etc.

Links: are rigid bodies each having hinged holes or slot to be connected together by some means to constitute a mechanism which able to transmit motion or forces to some another locations.

KINEMATIC LINKS CAN BE DIVIDED INTO THREE TYPES. 1. Rigid link- In this type of link there is no deformation while transmitting the motion. Motion between the piston and crank can be considered as a rigid link. 2. Flexible link- In this type of link there is partial deformation while transmitting the motion. Belt drive is an example of flexible link. 3. Fluid link- In this type of link the motion is transmitted with the help of fluid pressure. Hydraulic brake is an example of fluid link.

KINEMATIC PAIRS:- The two links or elements of a machine, when in contact with each other, are said to form a pair. If the relative motion between them is completely or successfully constrained (i.e. in a definite direction), the pair is known as kinematic pair. Let us discuss the various types of constrained motions.

CONSTRAINED MOTIONS

Types of Constrained Motions • Completely constrained motion • Incompletely constrained motion • Successfully constrained motion.

- (i) **Completely constrained motion:** When the motion between a pair is limited to a definite direction irrespective of the direction of force applied.

Example:

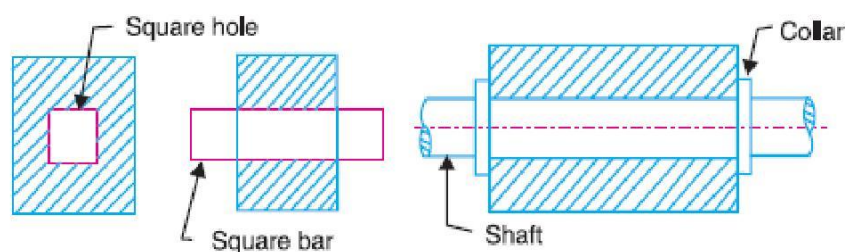

(ii) **Incompletely constrained motion:** When the motion between a pair can take place in more than one direction.

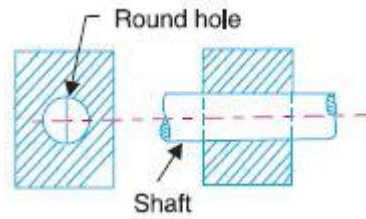

(iii) **Successfully / partially constrained motion:** When the motion between two elements of a pair is possible in more than one direction but is made to have motion only in one direction by using some external means.

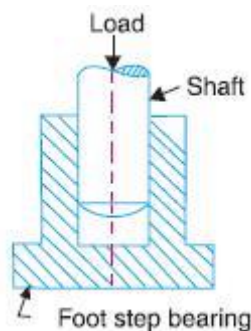

KINEMATIC CHAIN

When the kinematic pairs are coupled in such a way that the last link is joined to the first link to transmit definite motion (i.e. completely or successfully constrained motion), it is called a kinematic chain.

(c) **Inversion of Mechanism:** This is the method of obtaining different mechanisms by fixing different links in a kinematic chain.

Types of kinematic Chains:

- (i) Four Bar Chain / Quadric Cycle Chain
- (ii) Single Slider Crank Chain
- (iii) Double Slider Crank Chain

KINEMATIC INVERSION

Inversions of mechanism: A mechanism is one in which one of the links of a kinematic chain is fixed. Different mechanisms can be obtained by fixing different links of the same kinematic chain. These are called as inversions of the mechanism. By changing the fixed link, the number of mechanisms which can be obtained is equal to the number of links. Excepting the original mechanism, all other mechanisms will be known as inversions of original mechanism. The inversion of a mechanism does not change the motion of its links relative to each other.

Four Bar Chain / Quadric Cycle Chain:

- It consists of four rigid links which are connected in the form of a quadrilateral by four pin-joints.

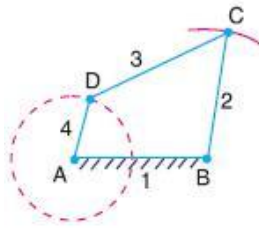

- A link makes complete revolution is called Crank (4).
- The link which is fixed is called fixed link (1).
- The link opposite to the fixed link is called Coupler (3).
- The fourth link is called Lever or Rocker (2).

Inversions of Four Bar Chain:

1. First Inversion (Crank & Lever Mechanism):

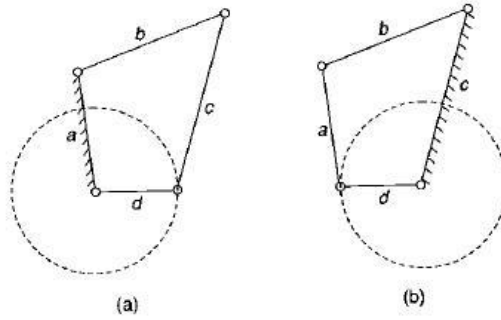

- ⌚ If any of the adjacent links of link d, i.e., **link a or c** is fixed. The link d (crank) can have full revolution and the link (b) opposite to it oscillates.

Application: Beam Engine (Crank & Lever Mechanism):

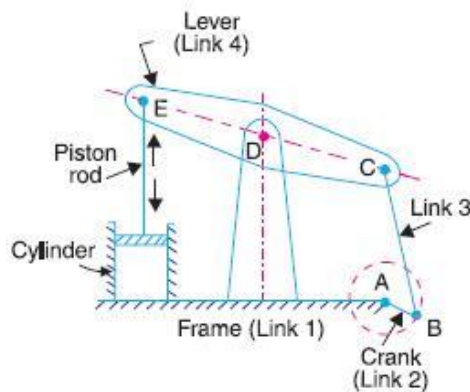

- ⌚ When the crank rotates about the fixed centre A and the lever oscillates about a fixed centre D.
- ⌚ The purpose of this mechanism is to convert rotary motion into reciprocating motion.

2. Second Inversion (Double Crank mechanism):

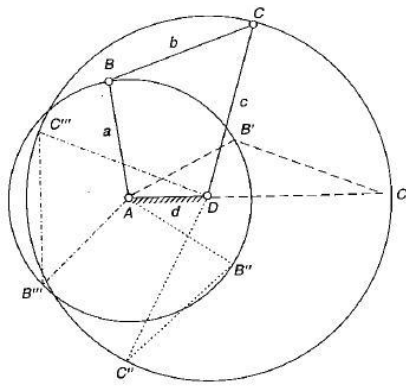

- ⌚ If the shortest **link (d)** is fixed then the links a and c rotates full circle and link b also complete one revolution relative to fixed link d.

Application: Coupling Rod of a Locomotive (Double Crank Mechanism):

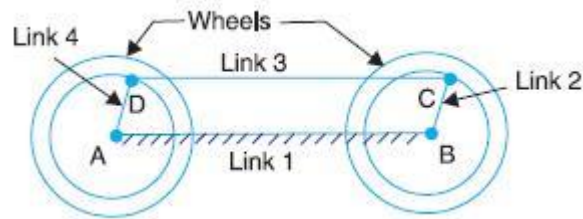

⌚ It is meant for transmitting rotary motion from one wheel to the other wheel.

3. Third Inversion (Double Lever Mechanism):

⌚ If the link opposite to the shortest link. i.e., **link b** is fixed and the two links a and c would oscillate.

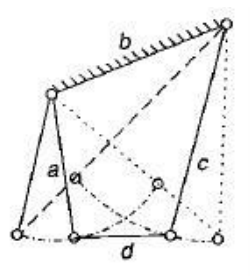

Application: Watt's indicator (Double Lever Mechanism):

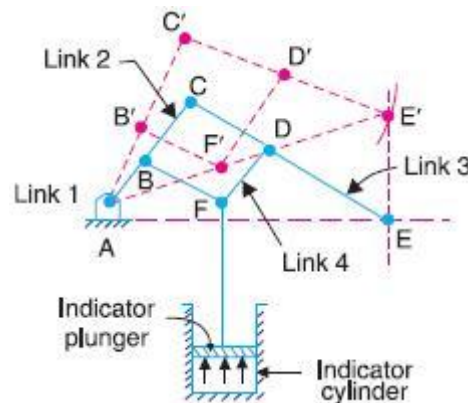

- ⌚ It consists of four links which are: Fixed link at A, link AC, link CE and link BFD. The links CE and BFD act as lever.
- ⌚ It is also called Watt's straight line mechanism and the dotted line shows the position of the mechanism.

Single Slider Crank Chain:

- ⌚ When one of the turning pairs of a four bar chain is replaced by a sliding pair, it becomes a single slider crank chain.
- ⌚ It consists of one sliding pair and three turning pairs.

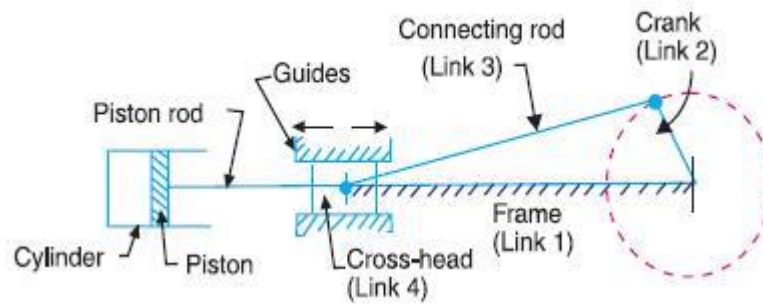

- ⌚ In a single slider crank chain as shown in the above figure, the links 1&2, links 2&3, and links 3&4 form three turning pairs while the links 4&1 form a slider pair.

Inversions of Single Slider Crank Chain:

1. First Inversion :

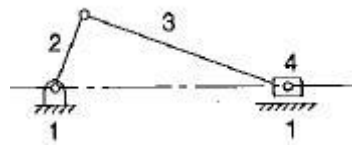

- ⌚ This inversion is obtained when **link 1** is fixed and links 2 & 4 are made the crank & the slider respectively.

Application:

1. Reciprocating Steam Engine: Link 4 (piston) is the driver.
2. Reciprocating Compressor. Link 2 (crank) is the driver.

2. Second Inversion:

- ⌚ This inversion is obtained when link 2 is fixed; link 3 along with the slider becomes crank and link 1 rotate about O along with the slider which also reciprocates on it.

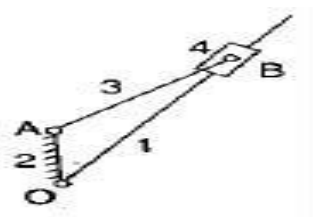

⌚ Application:

1. Whitworth quick-return mechanism:

- ⌚ This mechanism used in shaping and slotting machines.
- ⌚ In this mechanism the link CD (link 2) forming the turning pair is fixed; the driving crank CA (link 3) rotates at a uniform angular speed and the slider (link 4) attached to the crank pin at A slides along the slotted bar PA (link 1) which oscillates at D.
- ⌚ The connecting rod PR carries the ram at R to which a cutting tool is fixed and the motion of the tool is constrained along the line RD produced.
- ⌚ The length of effective stroke = 2 PD. And mark $P_1R_1 = P_2R_2 = PR$.

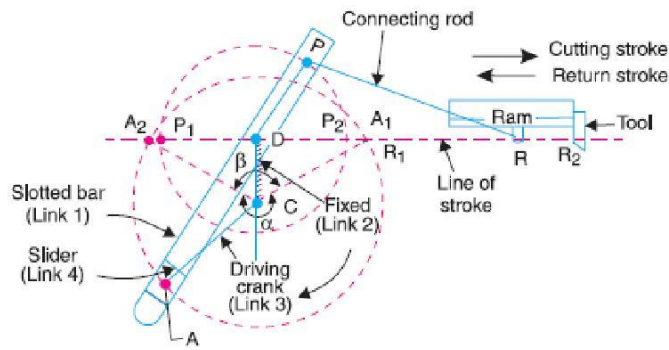

$$\frac{\text{Time of cutting stroke}}{\text{Time of return stroke}} = \frac{\alpha}{\beta} = \frac{\alpha}{360^\circ - \alpha} \quad \text{or} \quad \frac{360^\circ - \beta}{\beta}$$

2. Rotary internal combustion engine / Gnome engine:

- ⌚ This mechanism is used in aviation.
- ⌚ It consists of seven cylinders in one plane and all revolves about fixed centre D.
- ⌚ The crank 2 is fixed, connecting rod 4 rotates and the piston 3 reciprocates inside the cylinders forming link 1.

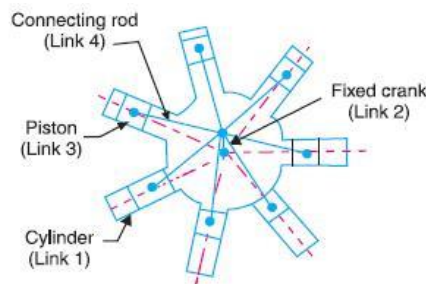

3. Third Inversion:

- ⌚ This inversion is obtained when the link 3 is fixed, the link 2 acts as a crank and link 4 oscillates.

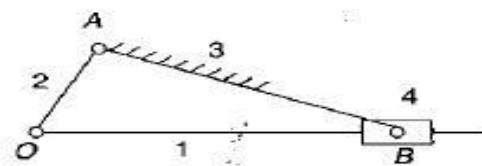

⌚ Application:

1. Oscillating cylinder engine:

- ⌚ It is used to convert reciprocating motion into rotary motion.

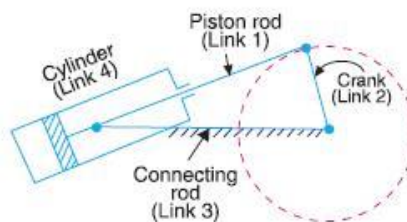

- ⌚ In this mechanism link 3 is fixed, the crank 2 rotates, piston rod 1 reciprocates and cylinder 4 oscillates about A.

2. Crank & slotted lever mechanism:

- ⌚ This mechanism is used in shaping machines, slotting machines and in rotary internal combustion engine.

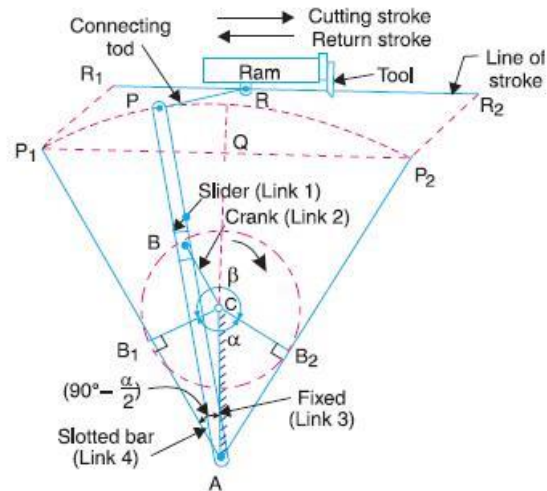

- ⌚ In this mechanism link AC(3) corresponding to the connecting rod is fixed, the driving crank CB revolves about the fixed centre C and a sliding block attached to the crank pin at B slides along the slotted bar AP.
- ⌚ AP oscillates about A and a short link PR transmits motion from AP to the arm which reciprocates along the line of stroke R_1R_2 .

$$\frac{\text{Time of cutting stroke}}{\text{Time of return stroke}} = \frac{\beta}{\alpha} = \frac{\beta}{360^\circ - \beta} \quad \text{or} \quad \frac{360^\circ - \alpha}{\alpha}$$

$$\text{Length of stroke} = R_1R_2 = P_1P_2 = 2P_1Q = 2AP \cos \frac{\alpha}{2} = 2AP \times \frac{CB_1}{AC} = 2AP \times \frac{CB}{AC}$$

4. Fourth Inversion:

- ⌚ This inversion is obtained when the link 4 is fixed, the link 3 oscillates about B on the link 4 and the end A of the link 2 is oscillates about B and the end O reciprocates along the fixed link 4.

⌚ Application: Hand-Pump:

- ⌚ The link 4 is made in the form of a cylinder and a plunger fixed to the link 1 reciprocates in it.

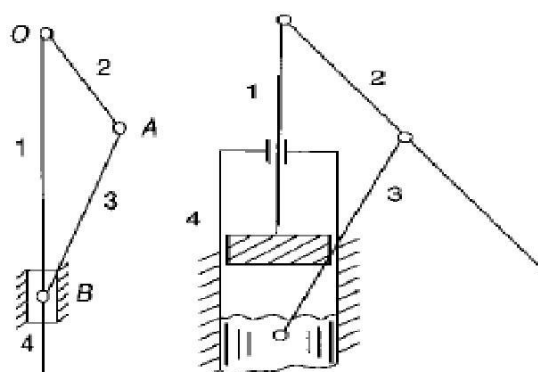

Flywheel

A **flywheel** is a mechanical device specifically designed to efficiently store rotational energy. Flywheels resist changes in rotational speed by their moment of inertia. The amount of energy stored in a flywheel is proportional to the square of its rotational speed. The way to change a flywheel's stored energy is by increasing or decreasing its rotational speed by applying a torque aligned with its axis of symmetry. Application of slider-crank mechanism can be found in reciprocating (steam) engines in the power plant i.e. internal combustion engines, generators to centrifugal pumps, etc. Output is non-uniform torque from crankshaft; accordingly there will be fluctuation in speed and subsequently in voltage generated in the generator that is objectionable or undesirable. Output torque at shaft is required to be uniform. Other kind of applications can be in punch press. It requires huge amount of power for small time interval. Remaining time of cycle it is ideal. Large motor that can supply huge quantity of energy for a small interval is required. Output power at piston is required to be non-uniform. These can be overcome by using flywheel at the crank- shaft. This will behave like a reservoir of energy. This will smoothen out the non-uniform output torque from crankshaft. Also it will store energy during the ideal time and redistribute during the deficit period.

Turning moment diagrams and fluctuations of the crank shaft speed: A turning moment (crank torque) diagram for a four-stroke internal combustion engine is shown in Figure 1. The complete cycle is of 720° . From the static and inertia force analyses $T - \theta$ can be obtained (at

Engine turning moment diagram:

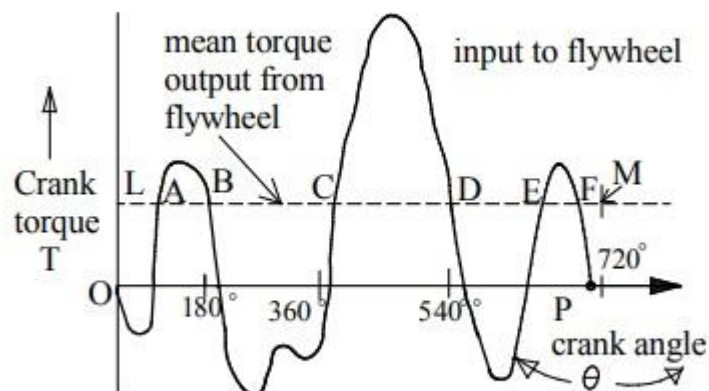

Figure 1 Turning moment diagram

interval of 15° or 5° preferably).

Torque is negative in some interval of the crank angle, it means energy is supplied to engine during this period i.e. during the compression of the gas and to overcome inertia forces of engine members. This is supplied by the flywheel (and inertia of engine members), which is attached to the crankshaft. When flywheel is attached to the crankshaft. LM in diagram shown is the mean torque line.

HOOKE'S JOINT

A universal joint also known as universal coupling, U joint, Cardan joint, Hardy-Spicer joint, or Hooke's joint is a joint or coupling used to connect rotating shafts that are coplanar, but not coinciding. A universal joint is a positive, mechanical connection used to transmit motion, power or both. Each universal joint assembly consists of three major components: two yokes (flange and weld) and a cross trunnion. An automotive flange yoke has a machined flat face which may be affixed through a bolted connection to the rear differential of a vehicle. A weld yoke incorporates a machined step, and is inserted into the end of the driveshaft and welded in place. The cross trunnion is used to deliver rotation from one yoke to another using four needle bearing.



Typical Universal Joint

POWER TRANSMISSION

Belts are the cheapest utility for power transmission between shafts that may not be axially aligned. Power transmission is achieved by specially designed belts and pulleys. The demands on a belt-drive transmission system are huge, and this has led to many variations on the theme. They run smoothly and with little noise, and cushion motor and bearings against load changes, albeit with less strength than gears or chains. However, improvements in belt engineering allow use of belts in systems that only formerly allowed chains or gears.

Power transmitted between a belt and a pulley is expressed as the product of difference of tension and belt velocity:

$$P = (T_1 - T_2)v,$$

where, T_1 and T_2 are tensions in the tight side and slack side of the belt respectively. They are related as

$$\frac{T_1}{T_2} = e^{\mu\alpha},$$

where, μ is the coefficient of friction, and α is the angle (in radians) subtended by contact surface at the centre of the pulley.

Flat belts

Flat belts were widely used in the 19th and early 20th centuries in line shafting to transmit power in factories. Flat belts are still used today, although not nearly as much as in the line-shaft era. The flat belt is a simple system of power transmission that was well suited for its day. It can deliver high power at high speeds (500 hp at 10,000 ft/min, or 373 kW at 51 m/s), in cases of wide belts and large pulleys.

V belts

V belts (also style V-belts, vee belts, or, less commonly, wedge rope) solved the slippage and alignment problem. It is now the basic belt for power transmission. They provide the best combination of traction, speed of movement, load of the bearings, and long service life. They are generally endless, and their general cross-section shape is roughly trapezoidal (hence the name "V"). The "V" shape of the belt tracks in a mating groove in the pulley (or sheave), with the result that the belt cannot slip off. The belt also tends to wedge into the groove as the load increases—the greater the load, the greater the wedging action—improving torque transmission and making the V-belt an effective solution, needing less width and tension than flat belts. V-belts trump flat belts with their small center distances and high reduction ratios. The preferred center distance is larger than the largest pulley diameter, but less than three times the sum of both pulleys. Optimal speed range is 1,000–7,000 ft/min (300–2,130 m/min). V-belts need larger pulleys for their thicker cross-section than flat belts.

For high-power requirements, two or more V-belts can be joined side-by-side in an arrangement called a multi-V, running on matching multi-groove sheaves. This is known as a multiple-V-belt drive (or sometimes a "classical V-belt drive").

GEAR TRAIN:-

Sometimes, two or more gears are made to mesh with each other to transmit power from one shaft to another. Such a combination is called gear train or train of toothed wheels. The nature of the train used depends upon the velocity ratio required and the relative position of the axes of shafts. A gear train may consist of spur, bevel or spiral gears.

Types of Gear Trains: Following are the different types of gear trains, depending upon the arrangement of wheels: 1. Simple gear train, 2. Compound gear train, 3. Reverted gear train, and 4. Epicyclic gear train. In the first three types of gear trains, the axes of the shafts over which the gears are mounted are fixed relative to each other. But in case of epicyclic gear trains, the axes of the shafts on which the gears are mounted may move relative to a fixed axis.

Simple gear train	Compound gear train	Elliptical gear train
Only one gear in each shaft and there is a relative motion between shaft axis.	In this gear there is more than one gear on the shaft which is rigidly fix and meshed with the gear on another shaft forming gear train.	The axis of shaft on which the gear are mounted may move relative to the fixed axis.
For large speed reduction, large size of gear is required.	For large speed reduction the small gear ratio is required.	For large speed reduction in high velocity moderate size gear is required.

VEHICLE IN MOTION

Resistance faced by the vehicle **a. Air resistance:-** It is resistance offered by air to the forward movement of vehicle. This resistance has an influence on performance, ride and stability of the vehicle. Wind or air resistance depends upon speed, shape of the vehicle body and wind velocity.

b. Rolling resistance:-It is resistance caused by friction between road and tyres which opposes the motion of the vehicle. The magnitude of rolling resistance depends mainly on the nature of road surface, the types of tyres, the weight of the vehicle and the speed of the vehicle.

c. Traction The condition of friction as between the tyre and the surface of the roadway, the holding of the tyre on the roadway, the ability to transmit power from the tyre to the roadway. OR The ability of the drive wheels to transmit tractive effort without slipping is know as traction

d. Tractive efforts The force available at the contact between the drive wheel tyres and road is known as tractive effort.

e. Drawbar pull Drawbar pull is the amount of horizontal force available to a vehicle at the

drawbar for accelerating or pulling a load. Drawbar pull the difference between tractive effort available and tractive effort required to overcome resistance at a specified speed.

f. Gradeability The maximum percentage grade, which a vehicle can negotiate with full rated condition, is known as gradeability. $\text{Gradeability} = \frac{100}{W} (\text{Tractive effort} - \text{Road resistance}) = \frac{100}{W} (F - R)$

VEHICLE CONTROL

Forces & Braking

When a car is travelling at a steady speed the frictional forces (like air resistance) are balanced by the driving force of the engine. The resultant force is zero.

The greater the speed of the car the greater the stopping distance.

Stopping distance

The overall stopping distance for a car is made up of two components the thinking distance and the braking distance.

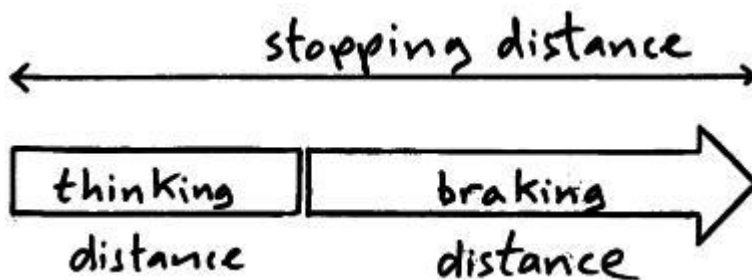

$\text{stopping distance (m)} = \text{thinking distance (m)} + \text{braking distance (m)}$

Thinking distance

This is the distance the car travels forward from the moment they see a problem to the moment they put their foot on the brake, it is determined by the reaction time of the driver.

The thinking distance is longer (i.e. the reaction time is slower) if the driver is tired, is distracted, has taken alcohol or drugs.

Braking distance

The braking distance is the distance the car travels forward from the moment the car begins braking to the moment it has been brought to stop. The braking distance is longer if the road is wet or icy or the tyres and brakes are worn.

Energy in braking

The kinetic energy of the car is converted into thermal (heat) energy in the brakes by friction. If the car's wheels lock and the car slides the kinetic energy is converted into thermal (heat) energy because of friction between the tyres and the road.

BALANCING

Static Balance

The static wheel imbalance is best understood by mounting a wheel and tyre assembly on the hub of a wheel balancing machine. The assembly is then spun around by hand and released. The wheel spins a few times depending upon the momentum gained, before it stops momentarily and then starts to oscillate to and fro with decreasing amplitude until it comes to rest. If the lowest point of the tyre is marked with a chalk and is now turned in one direction to certain angle and then released, it immediately commences a to and fro oscillatory motion, until coming to rest with the chalk mark at the lowest point. This illustrates that the heaviest part of the wheel assembly always gravitates to the lowest position. A small magnetic weight, equivalent to the out of balance mass, is placed on the wheel rim diametrically opposite the heavy side of the wheel. Now if the wheel is rotated to any other position, it remains at rest in that position. However, if there is still a slight movement of the wheel on its own, then the magnetic weight attached is too small, or if the wheel oscillates faster than before the weight is too large. This process of either adding or reducing the amount of weight placed opposite the heavy side of wheel and then moving the wheel round about a quarter of a turn to observe if the wheel tries to rotate on its own is a simple and effective technique used to check and correct any wheel

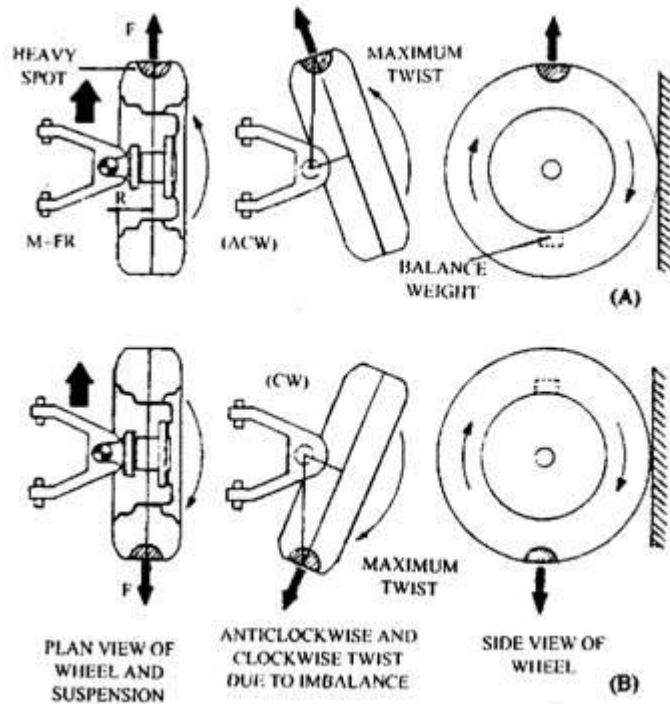

Illustration of static wheel imbalance.

imbalance on one plane. Once the correct balancing weight has been obtained, the magnetic weight is replaced with a clip-in weight of similar mass. With experience this trial and error method of statically balancing the wheel can be quick.

As a statically unbalanced wheel and tyre, rotates on a fixed circular path around its axis (Fig. 23.24), the heavy side of the wheel pulls radially outwards due to the centrifugal force. In case if the swivel pins and the centre of the unbalanced mass are offset to each other and if the heavy spot is in the horizontal plane pointing towards the front of the vehicle, then a moment of force is produced ($M = FR$), which tends to twist the stub axle and wheel assembly anticlockwise about the swivel pins (Fig. 23.24A). As the wheel rolls forward a further half turn, the heavy spot now faces towards the rear so that the stub axle and wheel assembly tries to swivel in the opposite direction (clockwise) (Fig. 23.24B). Therefore with a statically unbalanced tyre, the stub axle twists about its pivot every time the heavier side of the wheel completes half a revolution between the extreme points in the horizontal plane. The oscillations thus produced are transmitted in the form of tremors to the steering wheel. The frequency and magnitude of this tremor increases with rise of vehicles speed. When the swivel pin or king pin has excessive wear, the stub axle tends to move vertically up or down on its supporting joints. This may convey vibrations to the body through the suspension, which can be critical if allowed to resonate with

possibly the unsprung or sprung parts of the vehicle.

Dynamic Balance

If a driven drum is made to engage the tread of the tyre so that the wheel is spun through a speed range then the wheel is likely to develop a violent wobble, which peaks at some point and then decreases as the wheel speed rises.

The balance weight may be placed correctly opposite the heavy spot of the tyre, but on the wheel rim may be in a different rotational plane to that of the original out of balance mass.

Consequently the tyre heavy spots pull outwards in one plane while the balance weight of the

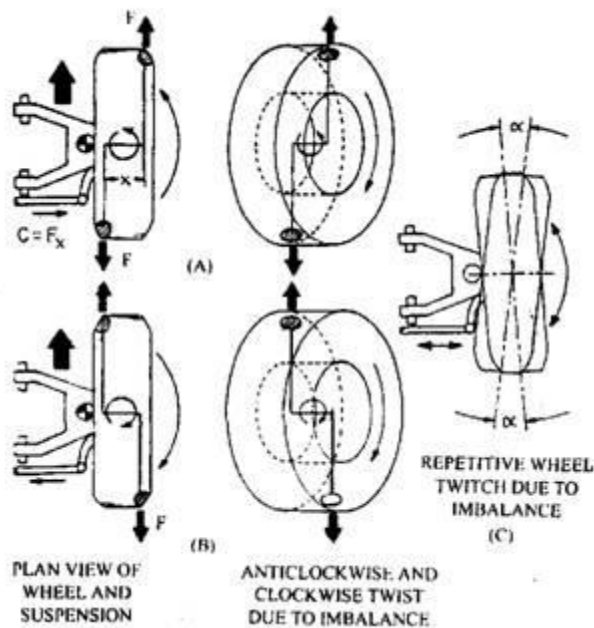

VIBRATIONS

Most machinery are subject to time varying forces which cause time dependent motions of the system. For example any mechanism such as used in a shaper machine, lathe, grinder etc involves moving masses that accelerate and decelerate in addition to time dependent cutting forces. A building or a nuclear reactor structure subjected to an earthquake undergoes time dependent deformations and stresses. A crankshaft of a multi-cylinder IC engines used in most cars is continuously subjected to time dependent torques. On the other hand, an aircraft at the time of landing is subject to tremendous impact forces that act for an extremely short duration of time. An automobile is subjected to crushing forces over a few milli-seconds whenever an accident takes place. Acceleration and deceleration of masses causes inertia forces as we have discussed at length when we looked at the problem of

balancing. If we are dealing with only rigid bodies, it is essentially a problem of balancing alone i.e., we aim to minimize unbalanced forces. However most systems are not rigid – for example, for all practical purposes, a building appears quite sturdy and rigid but when an earthquake hits, the whole building shakes as a deformable body and may actually break down. On the other hand automobiles have speciallybuilt-in springy elements in the form of suspension/shock absorbers and when negotiating rough roads, the automobile undergoes vibratory oscillations. While the suspension spring is an example of a concentrated dose of springiness in a system lumped at one place in one device, springiness (elastic or plastic) is actually present throughout the body of the vehicle. This becomes apparent when a car hits an obstacle and the body of the vehicle gets dented (plastically deformed).

TYPES OF VIBRATIONS

1. free vibration
2. forced vibration
3. damped vibration &
4. forced damped vibration